

II-VI



APA7501010009

850nm 10Gb/s Multimode VCSEL Chip

Features:

- 850nm multimode emission
- Low RMS spectral width
- High reliability
- Low threshold and operation current
- Low electrical parasitics
- Data rates up to 10 Gb/s
- Backside cathode and topside anode configuration
- RoHS compliant 

Applications:

- Fiber optical communication links up to 10 Gb/s
- Gigabit Ethernet and storage area networks

Shipment packaging options:

- Diced wafer on UV tape on metal lead frame
- Grip ring
- Gel-Pak

850nm 10Gb/s Multimode VCSEL Chip

Electro-Optical Characteristics

T=25°C unless otherwise noted

Parameter	Symbol	Conditions	Ratings			Unit
			Min	Typ	Max	
Threshold current	I_{th}			0.7	1.0	mA
Operating current	I_{op}		5.0		6.0	mA
Slope efficiency	η	$I = I_{th} + 1\text{mA}$	0.35	0.44	0.53	mW/mA
Optical output power	P_{out}	$I_{op} = 6\text{mA}$	1.7	2.2	2.7	mW
Operating voltage	U_{op}	I_{op}		1.9		V
Differential resistance	R_d	I_{op}	45	60	75	Ω
Emission wavelength	λ	$I_{op}, T = -5^\circ\text{C} - 90^\circ\text{C}$	840	850	860	nm
Spectral width, RMS	$\Delta\lambda$	$I_{op}, T = -5^\circ\text{C} - 90^\circ\text{C}$		0.25	0.35	nm
Beam divergence	Θ	$I_{op}, \text{Full width } 1/e^2$		24	30	°
Capacitance	C	I_{op}		0.25	0.35	pF
Modulation bandwidth	f_{3dB}	I_{op}	9			GHz
Rise time	t_r	$I_{op}, ER=5\text{dB}, 20\% - 80\%$		30	40	ps
Fall time	t_f	$I_{op}, ER=5\text{dB}, 20\% - 80\%$		40	45	ps
Relative Intensity Noise	RIN(OMA)	$I_{op}, ER=5\text{dB}, 7.7\text{GHz bandwidth}$			-128	dB/Hz

Thermal Characteristics

Parameter	Symbol	Ratings			Unit
		Min	Typ	Max	
Wavelength tuning coefficient	$\delta\lambda/\delta T$		0.06		nm/K
Slope efficiency variation 25°C - 85°C	$\Delta\eta_T$	-0.5	-0.3	-0.1	%/K
Thermal impedance	Z_{th}		3.0		K/mW

Absolute Maximum Ratings

Parameter	Rating	Unit
Optical output power	8	mW
Peak forward current (max. 10sec)	12	mA
VCSEL reverse voltage	5	V
Operating temperature	-5 to +90	°C
Storage temperature	-40 to +100	°C
Mounting temperature (max. 10sec)	260	°C

850nm 10Gb/s Multimode VCSEL Chip

Chip Outer Dimensions

Parameter	Min	Typ	Max	Unit
Die length	170	190	210	μm
Die width	170	190	210	μm
Die height	135	150	165	μm

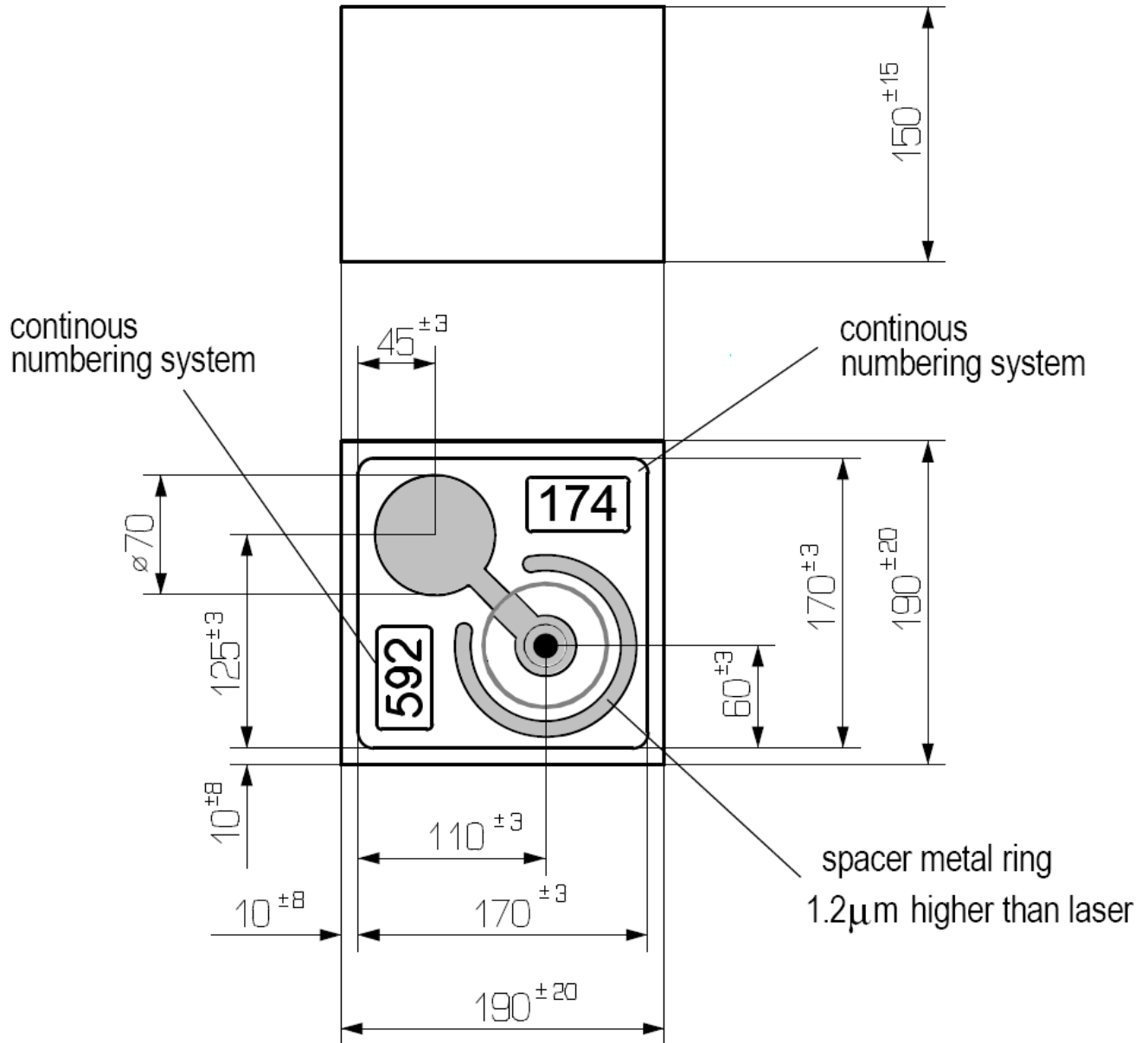

850nm 10Gb/s Multimode VCSEL Chip

RoHS Compliance

II-VI is fully committed to environment protection and sustainable development and has set in place a comprehensive program for removing polluting and hazardous substances from all of its products. The relevant evidence of RoHS compliance is held as part of our controlled documentation for each of our compliant products. RoHS compliance parts are available to order, please refer to the ordering information section for further details.

Ordering Information

Product Code	Data Rate	Description	Shipment Packaging
APA7501010009	10Gb/s	850nm 10G MM single VCSEL chip	Diced wafer on metal lead frame ⁽¹⁾
APA7501010109	10Gb/s	850nm 10G MM single VCSEL chip	Grip ring ⁽²⁾
APA7501010209	10Gb/s	850nm 10G MM single VCSEL chip	Gel-Pak ⁽³⁾

⁽¹⁾ Full diced 3" wafer on UV tape on metal lead frame Ø 230mm, electronic wafermap provided (standard high volume)

⁽²⁾ Known Good Dies on UV tape on grip ring Ø 150mm (medium volume)

⁽³⁾ Known Good Dies in 2" Gel-Pak (low volume)

Important Notice

Performance figures, data and any illustrative material provided in this data sheet are typical and must be specifically confirmed in writing by II-VI before they become applicable to any particular order or contract. In accordance with the II-VI policy of continuous improvement specifications may change without notice. Further details are available from any II-VI sales representative.

Safety Labels



Caution - use of controls or adjustments or performance of procedures other than those specified herein may result in hazardous radiation exposure.