

## 10Gb/s SFP+ Active Optical Cable / 10G-AOC-XXM

### Features:

- Support 10GBASE-SR/10G Fiber Channel application
- Compliant to SFP+ Electrical MSA SFF-8431
- Compliant to SFP+ Mechanical MSA SFF-8432
- Multi rate of up to 11.3Gbps
- Transmission distance up to 150m (OM3)
- +3.3V single power supply
- Low power consumption
- Operating case temp  
Commercial: 0°C to +70 °C
- RoHS compliant
- Password protection for A0h and A2h



### Applications

- 10GBASE-SR at 10.31Gbps
- InfiniBand QDR, SDR, DDR
- Other optical links

### Absolute Maximum Ratings

Table2- Absolute Maximum Ratings

Parameter	Symbol	Min.	Typical	Max.	Unit	Notes
Supply Voltage	Vcc <sub>3</sub>	-0.5	-	+3.6	V	
Storage Temperature	T <sub>s</sub>	-40	-	+85	°C	
Operating Humidity	RH	+5	-	+85	%	1
Receiver Damage Threshold	P Rdmg	+3.4	-	-	dBm	

Note1: No condensation

### Recommended Operating Conditions

Table 3- Recommended operating Conditions

Parameter	Symbol	Min.	Typical	Max.	Unit	Notes
Operating Case Temperature	T <sub>c</sub>	0	-	+70	°C	
Power Supply Voltage	Vcc	3.14	3.3	3.47	V	
Power Supply Current	Icc	-	-	150	mA	
Power Dissipation	Pd	-	-	0.6	W	
Bit Rate	BR	-	10.3125	-	Gbps	
Fiber Bend Radius	Rb	3	-	-	cm	

### Electrical Characteristics



**Table 4- Electrical Characteristics**

Parameter	Symbol	Min.	Typ.	Max.	Units	Notes	
<b>Transmitter</b>							
Differential Data Input Swing	$V_{in,P-P}$	200	-	1600	mV <sub>pp</sub>		
Input Differential Impedance	$Z_{IN}$	90	100	110	$\Omega$		
Tx_Fault	Normal Operation	$V_{OL}$	0	-	0.8	V	
	Transmitter Fault	$V_{OH}$	2.0	-	$V_{CC}$	V	
Tx_Disable	Normal Operation	$V_{IL}$	0	-	0.8	V	
	Laser Disable	$V_{IH}$	2.0	-	$V_{CC}+0.3$	V	
<b>Receiver</b>							
Differential Date Output	$V_{out}$	370	-	1600	mV		
Output Differential Impedance	$Z_D$	90	100	110	$\Omega$		
Rx_LOS	Normal Operation	$V_{OL}$	0	-	0.8	V	
	Lose Signal	$V_{OH}$	2.0	-	$V_{CC}$	V	

## Optical Characteristics

**Table 5-Optical Characteristics**

Parameter	Symbol	Unit	Min	Typ	Max	Notes
<b>Optical transmitter Characteristics</b>						
Data Rate	DR	Gbps	9.953	10.3125	11.3	
Center Wavelength Range	$\lambda_c$	nm	820	850	880	
Laser Off Power	P <sub>off</sub>	dBm	-	-	-45	
Launch Optical Power	P <sub>0</sub>	dBm	-6.0			1
Extinction Ratio	ER	dB	3	-	-	
Spectral Width(RMS)	RMS	nm	-		0.45	
<b>Optical Receiver Characteristics</b>						
Data Rate	DR	Gbps	9.953	10.3125	11.3	
Bit Error Rate	BER	dBm	-	-	E-12	2
Overload Input Optical Power	P <sub>IN</sub>	dBm	2.4	-	-	2
Center Wavelength Range	$\lambda_c$	nm	820	-	880	
Receiver Sensitivity in Average Power	Sen	dBm	-	-	-9.9	3
Los Assert	LosA	dBm	-26	-	-	
Los De-Assert	LosD	dBm	-	-	-12	
Los Hysteresis	LosH	dB	0.5	-	-	

Note:

1. Coupled into 50/125 MMF.
2. Measured with PRBS 2<sup>31</sup>-1 test pattern @10.3125Gbps.BER=10E-12

## Recommended Host Board Power Supply Circuit



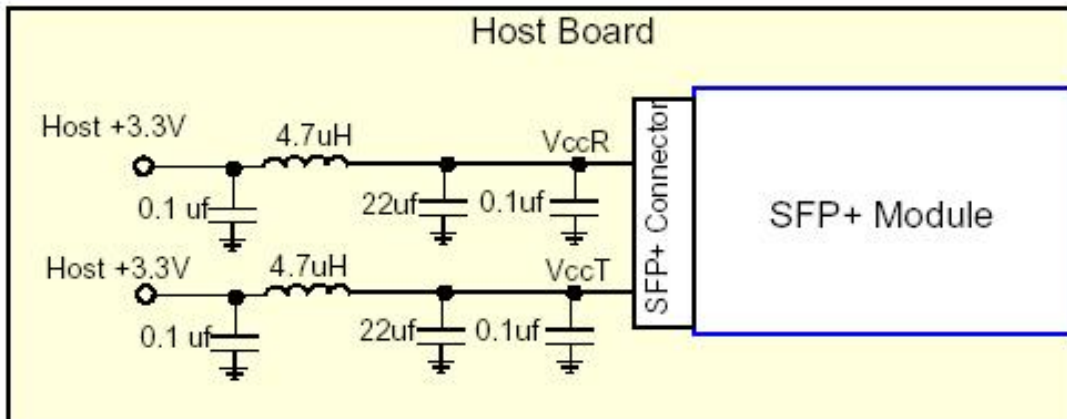

Figure 1, Recommended Host Board Power Supply Circuit

### Recommended Interface Circuit

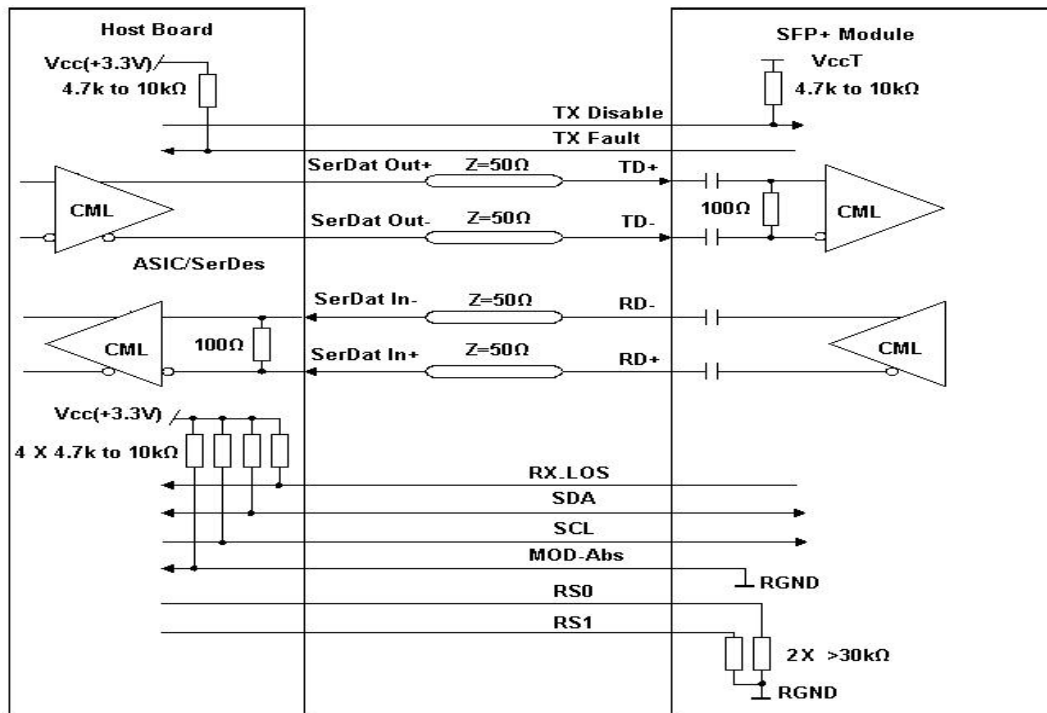

Figure 2, Recommended Interface Circuit

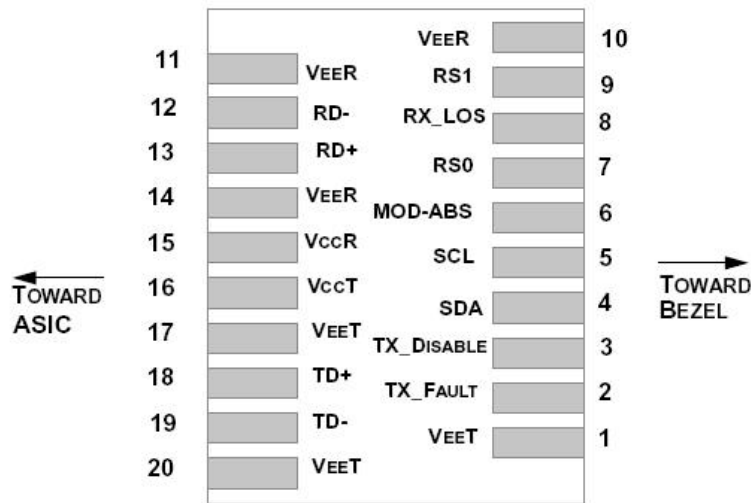

Figure 3, Pin View

Table 6-Pin Function Definitions

Pin	Symbol	Name/Description	Notes
1	VEET	Module Transmitter Ground	1
2	TX_FAULT	Module Transmitter Fault	2
3	TX_DISABLE	Transmitter Disable; Turns off transmitter laser output	3
4	SDA	2-Wire Serial Interface Data Line (MOD-DEF2)	
5	SCL	2-Wire Serial Interface Clock (MOD-DEF1)	
6	MOD_ABS	Module Absent, connected to VEET or VEER in the module	2
7	RS0	Rate Select 0, optionally controls SFP+ module receiver	
8	RX_LOS	Receiver Loss of Signal Indication (In FC designated as Rx_LOS and in Ethernet designated as NOT Signal Detect)	2
9	RS1	Rate Select 1, optionally controls SFP+ module transmitter	
10	VEER	Module Receiver Ground	1
11	VEER	Module Receiver Ground	1
12	RD-	Receiver Inverted Data Output	
13	RD+	Receiver Non-Inverted Data Output	
14	VEER	Module Receiver Ground	1
15	VCCR	Module Receiver 3.3 V Supply	
16	VcCT	Module Transmitter 3.3 V Supply	
17	VEET	Module Transmitter Ground	1
18	TD+	Transmitter Non-Inverted Data Input	
19	TD-	Transmitter Inverted Data Input	
20	VEET	Module Transmitter Ground	1

Note:

1. The module ground pins are isolated from the module case.
2. The pins shall be pulled up with 4.7K-10Kohms to a voltage between 3.14V and 3.46V on host board.
3. The pin is pulled up to VCCT with a 4.7K-10KΩ resistor in the module.

## Monitoring Specification

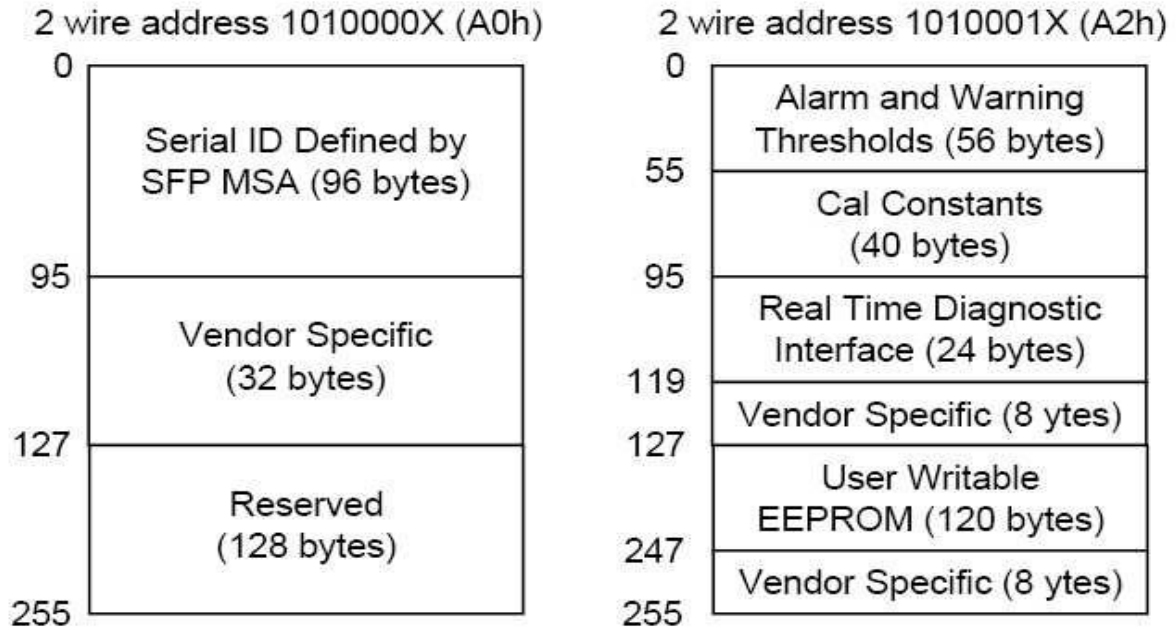

Figure 4, Memory Map

## Mechanical

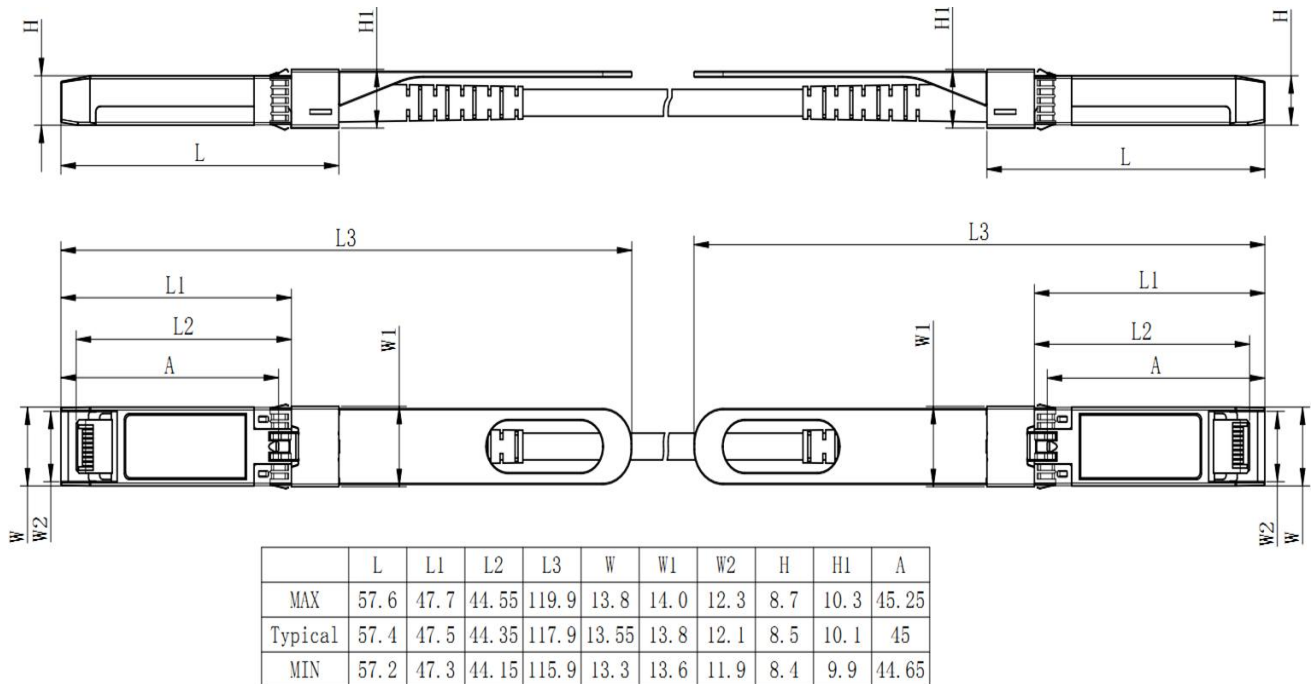

Figure 5, Mechanical Diagram

**Table 7-Cable Mechanical Specifications**

Parameter	Value	Units
Diameter	3	mm
Minimum bend radius	30	mm
Length tolerance	Length < 1 m:                    +5 / -0	cm
	1 m ≤ length ≤ 4.5 m:        +15 / -0	cm
	5 m ≤ length ≤ 14.5 m:       +30 / -0	cm
	Length ≥ 15.0 m                +2% / -0	m
Cable color	Aqua(OM3);Orange(OM2)	

**Revision history**

Version	Initiated	Reviewed	Revision	Release Date
A0	Ling	Zhang	New Release	2018-05-29
A1	Ling	Zhang	New structure	2018-12-21