

# 25G-AOC-XXM

## 25Gb/s SFP28 Active Optical Cable

### Features:

- Electrical interface compliant to SFF-8431
- 850nm VCSEL laser and PIN photo-detector
- Maximum link length of 70m on OM3 MMF and 100m on OM4 MMF
- Digital diagnostics functions are available via the I2C interface
- Operating case temperature  
Commercial: 0°C to +70 °C
- +3.3V single power supply
- Power consumption less than 1W
- RoHS compliant
- Password protection for A0h and A2h



### Applications

- 25GBASE-SR Ethernet
- Servers, switches, storage and host card adapters

### Absolute Maximum Ratings

Table2- Absolute Maximum Ratings

Parameter	Symbol	Min.	Typical	Max.	Unit	Notes
Supply Voltage	V <sub>CC3</sub>	-0.5	-	+3.6	V	
Storage Temperature	T <sub>s</sub>	-40	-	+85	°C	
Operating Humidity	RH	5	-	85	%	1

Note: 1 No condensation

### Recommended Operating Conditions

Table 3- Recommended operating Conditions

Parameter	Symbol	Min.	Typical	Max.	Unit	Notes
Operating Case Temperature	T <sub>c</sub>	0	-	+70	°C	
Power Supply Voltage	V <sub>CC</sub>	3.14	3.3	3.47	V	
Power Supply Current	I <sub>CC</sub>	-	-	300	mA	
Power Dissipation	P <sub>d</sub>	-	-	1.0	W	
Bit Rate	BR	8.5	25.78125	-	Gbps	
Fiber Bend Radius	R <sub>b</sub>	3	-	-	cm	

### Electrical Characteristics

Table 4- Electrical Characteristics

Parameter	Symbol	Min.	Typ.	Max.	Units	Notes
<b>Transmitter</b>						
Differential Data Input Swing	$V_{in,P-P}$	200	-	1600	mV <sub>pp</sub>	
Input Differential Impedance	$Z_{IN}$	90	100	110	$\Omega$	
Tx_Fault	Normal Operation	$V_{OL}$	0	-	0.8	V
	Transmitter Fault	$V_{OH}$	2.0	-	$V_{CC}$	V
Tx_Disable	Normal Operation	$V_{IL}$	0	-	0.8	V
	Laser Disable	$V_{IH}$	2.0	-	$V_{CC}+0.3$	V
<b>Receiver</b>						
Differential Date Output	$V_{out}$	400	-	800	mV	
Output Differential Impedance	$Z_D$	90	100	110	$\Omega$	
Rx_LOS	Normal Operation	$V_{OL}$	0	-	0.8	V
	Lose Signal	$V_{oH}$	2.0	-	$V_{CC}$	V

## Optical Characteristics

Table 5-Optical Characteristics

Parameter	Symbol	Unit	Min	Typ	Max	Notes
<b>Optical transmitter Characteristics</b>						
Bit Rate	BR	Gbps	8.5	25.78125	-	
Center Wavelength Range	$\lambda_c$	nm	820	850	880	
Average Launch power Tx_off	Poff	dBm	-	-	-45	
Launch Optical Power	$P_0$	dBm	-6.0		2.4	1
Extinction Ratio	ER	dB	2	-	-	
Spectral Width(RMS)	RMS	nm	-	-	0.65	
<b>Optical Receiver Characteristics</b>						
Bit Rate	BR	Gbps	8.5	25.78125		
Bit Error Rate	BER		-	-	E-12	
Damage threshold	DT	dBm	3.4	-	-	
Overload Input Optical Power	$P_{IN}$	dBm	2.4	-	-	2
Center Wavelength Range	$\lambda_c$	nm	820	-	880	
Receiver Sensitivity in Average Power	Sen	dBm	-	-	-5.2	3
Los Assert	LosA	dBm	-30	-	-	
Los De-Assert	LosD	dBm	-	-	-13	
Los Hysteresis	LosH	dB	0.5			

Note:

1. Coupled into 50/125 MMF.
2. Measured with PRBS 2<sup>31</sup>-1 test pattern @25.78125Gbps.BER=E-12
3. BER=1x10<sup>-12</sup>; PRBS2<sup>31</sup>-1@25.78125Gbps.

## Recommended Host Board Power Supply Circuit

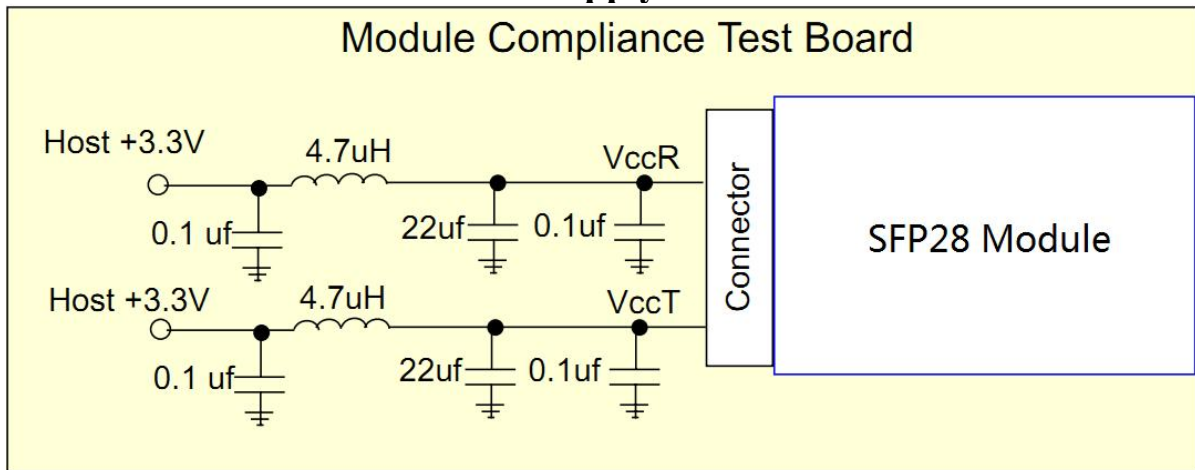

Figure 1, Recommended Host Board Power Supply Circuit

## Recommended Interface Circuit

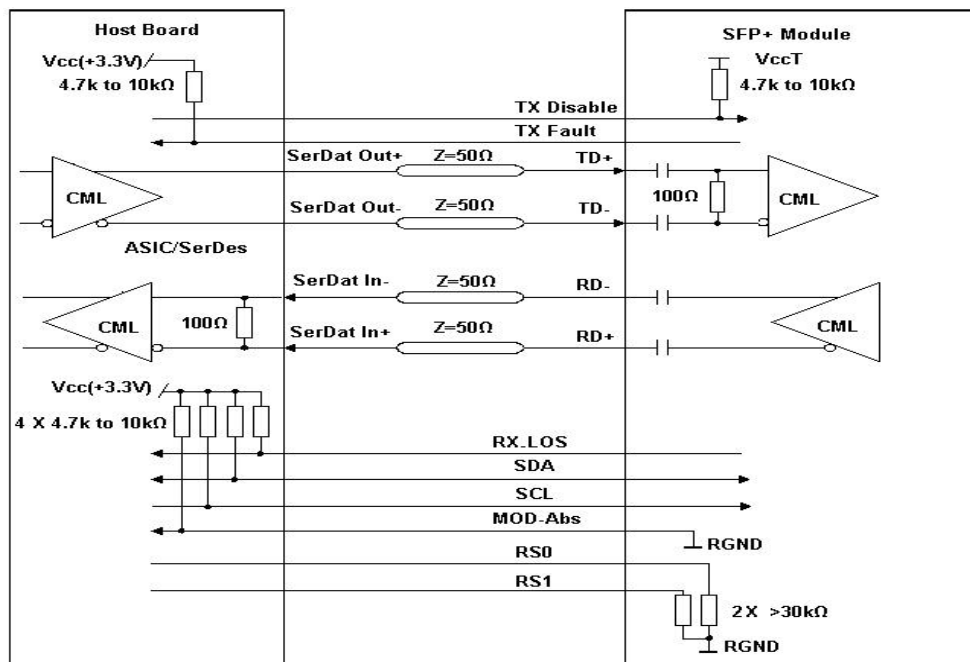

Figure 2, Recommended Interface Circuit

## Pin arrangement

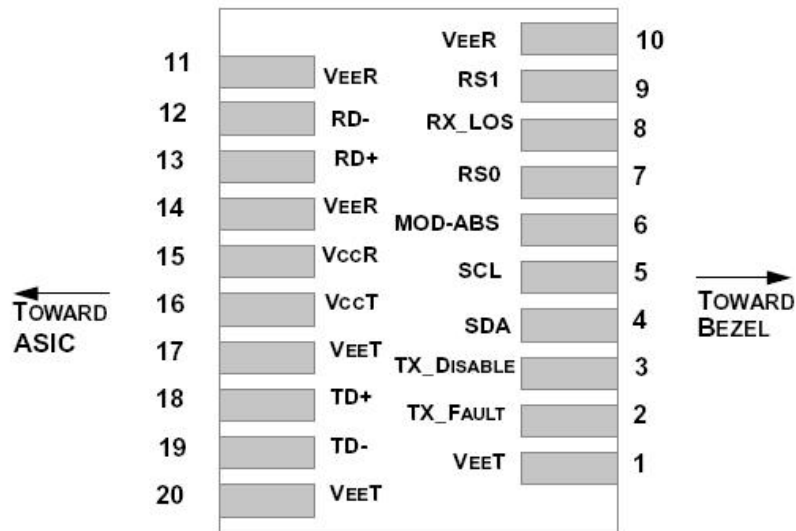

Figure 3, Pin View

Table 6-Pin Function Definitions

Pin	Symbol	Name/Description	Notes
1	VEET	Module Transmitter Ground	1
2	TX_FAULT	Module Transmitter Fault	2
3	TX_DISABLE	Transmitter Disable; Turns off transmitter laser output	3
4	SDA	2-Wire Serial Interface Data Line (MOD-DEF2)	
5	SCL	2-Wire Serial Interface Clock (MOD-DEF1)	
6	MOD_ABS	Module Absent, connected to V <sub>EE</sub> T or V <sub>EE</sub> R in the module	2
7	RS0	Rate Select 0, optionally controls SFP+ module receiver	4
8	RX_LOS	Receiver Loss of Signal Indication (In FC designated as Rx_LOS and in Ethernet designated as NOT Signal Detect)	2
9	RS1	Rate Select 1, optionally controls SFP+ module transmitter	4
10	VEER	Module Receiver Ground	1
11	VEER	Module Receiver Ground	1
12	RD-	Receiver Inverted Data Output	
13	RD+	Receiver Non-Inverted Data Output	
14	VEER	Module Receiver Ground	1
15	V <sub>CC</sub> R	Module Receiver 3.3 V Supply	
16	V <sub>CC</sub> T	Module Transmitter 3.3 V Supply	
17	VEET	Module Transmitter Ground	1
18	TD+	Transmitter Non-Inverted Data Input	
19	TD-	Transmitter Inverted Data Input	
20	VEET	Module Transmitter Ground	1

Note:

1. The module ground pins are isolated from the module case.
2. The pins shall be pulled up with 4.7K-10Kohms to a voltage between 3.14V and 3.46V on host board.
3. The pin is pulled up to VCCT with a 4.7K-10KΩ resistor in the module.
4. See SFF-8472 Rev12.2 Table 10-2.

## Monitoring Specification

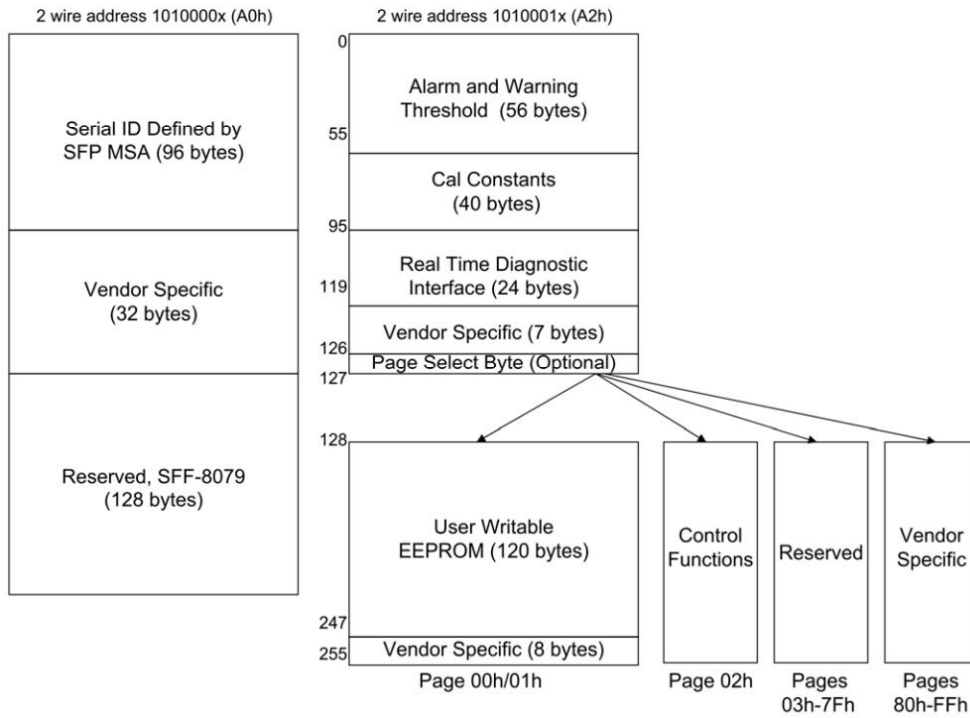

Figure 4, Memory Map

## Mechanical

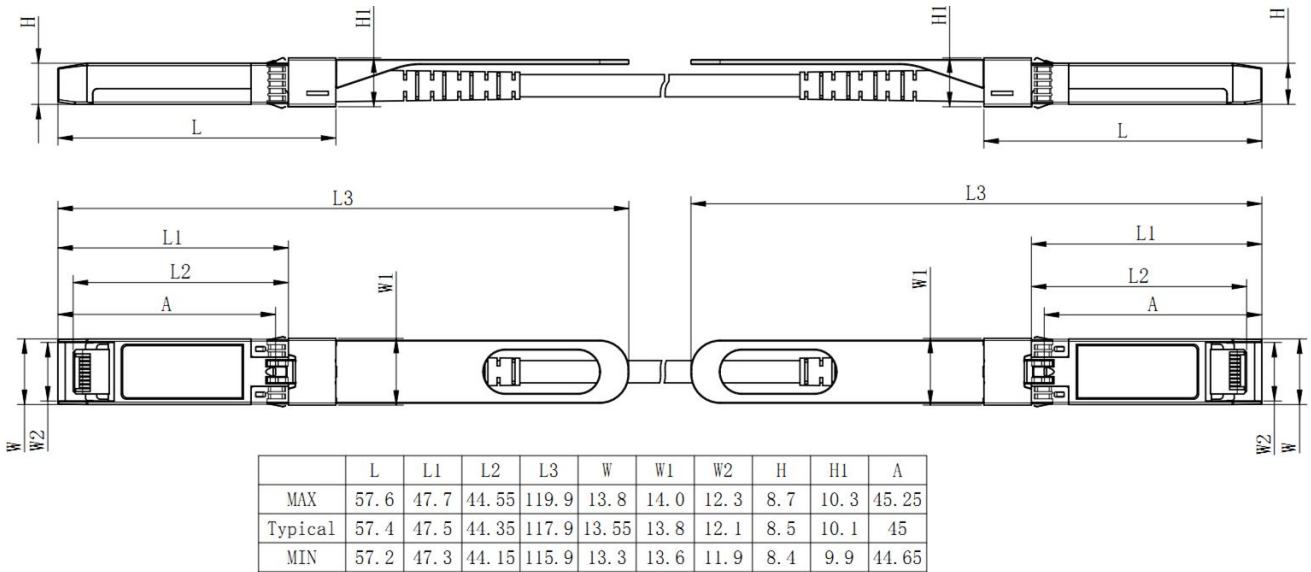

Figure 5, Mechanical Diagram

Table 7-Cable Mechanical Specifications

Parameter	Value	Units
-----------	-------	-------

Diameter	3	mm
Minimum bend radius	30	mm
Length tolerance	Length < 1 m:                   +5 / -0	cm
	1 m ≤ length ≤ 4.5 m:       +15 / -0	cm
	5 m ≤ length ≤ 14.5 m:       +30 / -0	cm
	Length ≥ 15.0 m               +2% / -0	m
Cable color	Aqua(OM3),Magenta(OM4)	

### Revision history

Version	Initiated	Reviewed	Revision	Release Date
A0	Ling	Zhang	New Release	2018-05-29
A1	Ling	Zhang	New structure	2018-12-21